

# OWNER'S MANUAL

## Model: FSBK-2 (5300975) (2-Nozzle Boom Kit w/7' Coverage)

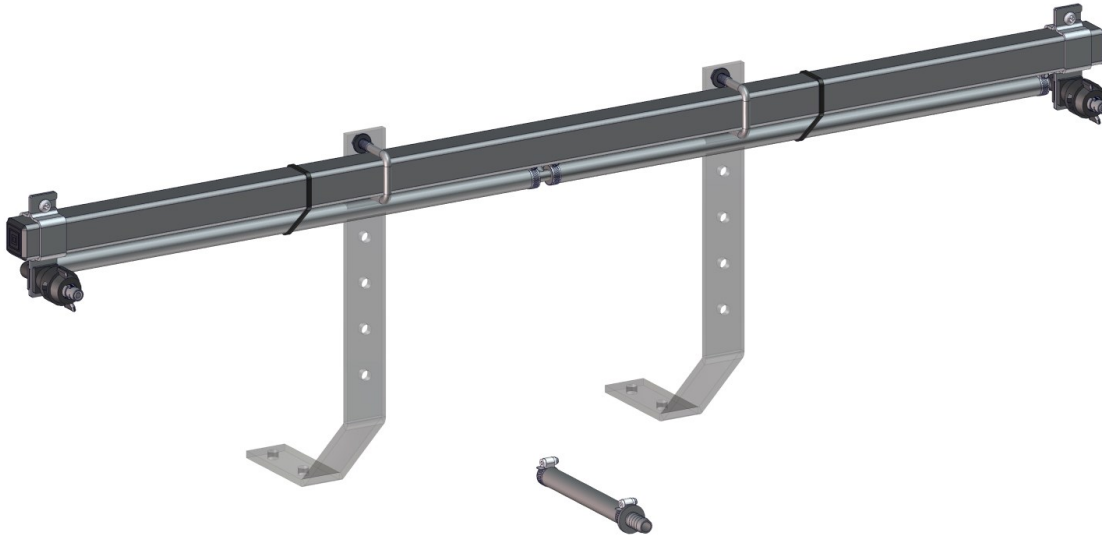

### General Information

Thank you for purchasing this product. The purpose of this manual is to assist you in operating and maintaining your boom.



**WARNING:** To reduce the risk of injury, the user must read and understand the operator's manual before using this product.



**WARNING:** Cancer and Reproductive Harm.  
[www.P65Warnings.ca.gov](http://www.P65Warnings.ca.gov)

#### BEFORE RETURNING THIS PRODUCT FOR ANY REASON, PLEASE CALL

<b>BAKERSFIELD, CA</b> 877-724-2236	<b>COLUMBUS, NE</b> 800-274-1025	<b>DOTHAN, AL</b> 800-227-4098
<b>FARGO, ND</b> 701-280-2862	<b>HOPKINSVILLE, KY</b> 800-637-7172	<b>MANKATO, MN</b> 507-388-6295
<b>NEWTON, KS</b> 800-394-7662	<b>PASCO, WA</b> 800-634-2026	<b>TEMPE, AZ</b> 877-974-7166

If you should have a question or experience a problem with your Ag Spray Product: Visit our website @ [www.agspray.com](http://www.agspray.com) or call the Toll free number above. Our technical support representatives will be happy to help you.

In most cases a customer service rep. can resolve the problem over the phone.

To obtain prompt, efficient service, always remember to give the following information....

- Correct Part Description and/or part number
- Model number and Serial Number

Part descriptions and numbers can be obtained from the illustrated parts list section(s) of this manual.

Retain a copy of your receipt for your unit, as it will be required to validate any warranty service.

Warranted against manufacturer or workmanship defects from date of purchase with copy of receipt:

Homeowner Usage: One Year

Commercial Usage: 90 Days.



[www.agspray.com](http://www.agspray.com)

[5004475

(12/22)]

## Contents

Technical Specifications and Assembly Instructions .....	2	Maintenance and Winter Storage .....	4
Operation .....	3	Exploded View/Parts List .....	5
Calibration.....	3 - 4	Warranty.....	6

## Model: FSBK-2 (5300975) (2-Nozzle Boom Kit w/7' Coverage)

### Technical Specifications

- 2-Nozzle Boom Assembly
- Corrosion-Resistant Nylon Nozzles
- Check Valve Strainers, 50 Mesh, 5 PSI

**These booms weighs approx. 13 Lbs.**

**Always check the vehicle load rating before using a boom with sprayer, ensuring total weight is acceptable.  
Do not exceed the recommended rating.**

### ~~~~~IMPORTANT~~~~~

It is VERY important to test the sprayer, after connecting a boom, with plain water before actual spraying is attempted. This will enable you to familiarize yourself with the sprayer and check for leaks without the possibility of losing any expensive chemicals.

### ~~~~~WARNING~~~~~



**Read and Understand** the Owner's Manual before using this boom. Test and use in accordance to instructions.

**Read and Follow** chemical label instructions and wear protective gear when filling, using, cleaning and servicing the boom.

**Exercise Caution** in vehicle handling when towing/hauling a filled sprayer to avoid loss of control or overturning.

**Keep Sprayer and Spray materials** away from other people, children and pets.

**Do Not Turn on Power** to the sprayer, until ready to spray in order to avoid unintentional spray release.

**Do Not Use** on steep slopes. A full sprayer could cause loss of control or overturn sprayer and vehicle.

**Always operate** up and down a slope, never across the face of a slope.

**Keep all movement on slopes** slow and gradual. Do not make sudden changes in speed, directions or turning. Do not start or stop suddenly when going uphill or downhill.

**Stop on level ground**, set the parking brake and shut off engine before leaving the operator's position for any reason.

**Keep all parts** in good condition and properly installed. Fix damaged or worn parts immediately.

**Caution should be taken** when towing and/or using any sprayer. The sprayer combined with the weight distribution, turning radius and speed of vehicle can result in damage to vehicle, sprayer and/or boom or severe injury or death, if not used properly.

**Improper use or handling of chemicals could result in serious injury or illness, or could cause damage to the environment.**

### Assembly Instructions

1. Attach the boom to your mounting brackets with the hardware provided. (2 square U-bolts & 4 whiz locknuts).
2. Affix your supply hose to the nylon TEE fitting on the nozzle harness and secure in place with a hose clamp.
3. Make sure all hose clamps are tight before testing or spraying for the first time.
4. Your boom should now be ready for operation.

**After assembling to the sprayer,  
boom will be ready to TEST w/plain water before actual use.**

### Testing the Sprayer

**NOTE:** It is VERY important for to test your sprayer with plain water before actual spraying is attempted. This will enable you to check for leaks without the possibility of losing any expensive chemicals.

### Operation

Always fill the tank 1/2 full with water first and then add the chemical slowly, mixing as you pour the chemical into the tank and then fill the rest of the way. You may use your handgun or the bypass line in order to mix the chemical and water.

Initially begin spraying by opening the handgun/boom. This will enable the air in the line to be purged through the handgun tip/boom tip, while building pressure.

### Adjusting Pressure

- When the bypass valve is closed, pressure is at the highest point.
- Opening the valve will decrease pressure.

Conditions of weather and terrain must be considered when setting the sprayer. Do not spray on windy days. Protective clothing must be worn in some cases

**Be sure to read the chemical label(s) before application!**

### Calibration

Chemical labels may show application rates in gallons per acre, gallons per 1000 square feet or gallons per 100 square feet. You will note that the tip chart shows 3 of these rating systems.

Once you know how much you are going to spray, then determine (from the tip chart) the spraying pressure (PSI), and the spraying speed (MPH).

Determining the proper speed of the pulling vehicle can be done by marking off 100, 200 & 300 feet. The speed chart indicates the number of seconds it takes to travel the distances. Set the throttle and with a running start, travel the distances. Adjust the throttle until you travel the distances in the number of seconds indicated by the speed chart. Once you have reached the throttle setting needed, mark the throttle location so you can stop and go again, returning to the same speed.

After testing, add water and proper amount of chemical to the tank and drive to the starting place for spraying. Adjust the pressure and spray as you did in the testing procedure.

Tip Chart for TKT-VP3, TF-VP3 & 30DT3.0 (Gray) Tips									
	Pressure (psi)	Capacity (GPM)	1 MPH	2 MPH	3 MPH	4 MPH	5 MPH	7.5 MPH	10 MPH
Gallons Per Acre Based on Water	10	.30	44	22	14.9	11.1	8.9	5.9	4.5
	20	.42	63	31.5	20.9	15.7	12.6	8.4	6.3
	30	.52	76	38	26	19.3	15.4	10.3	7.7
	40	.60	90	45	30	22	17.8	11.8	8.9
Gallons Per 1000 Sq. Ft. Based on Water	10	.30	1.01	.5	.34	.254	.204	.135	.103
	20	.42	1.4	.72	.48	.36	.29	.19	.14
	30	.52	1.74	.87	.596	.44	.35	.236	.176
	40	.60	2.06	1.00	.688	.50	.408	.27	.20
Gallons Per 100 Sq. Ft. Based on Water	10	.30	.10	.05	.034	.025	.02	.013	.01
	20	.42	.14	.072	.048	.036	.029	.019	.014
	30	.52	.174	.087	.059	.044	.035	.023	.017
	40	.60	.206	.10	.068	.05	.04	.027	.02

Speed Chart			
Speed in M.P.H. (Miles Per Hour)	Time Required in seconds to travel a distance of		
	100 Ft.	200 Ft.	300 Ft.
1.0	68 sec.	136	205
2.0	34	68	102
3.0	23	45	68
4.0	17	34	51
5.0	14	27	41
6.0	11	23	34
7.0	9.7	19	29
8.0	8.5	17	26
9.0	7.6	15	23
10.0	6.8	14	20

## Using the Boom Nozzle

Four things must be considered before spraying with the boom.

1. How much chemical must be mixed in the tank.
  2. Rate of spray (gallons per acre to be sprayed).
  3. What pressure (p.s.i.) will be used.
  4. Speed traveled (mph) while spraying.
- \* Refer to the chemical label to determine your chemical mixture
  - \* See the tip chart to determine the pressure to be used. The chart will also show the speed used when spraying.
  - \* Start the pump and open the valve to the boom nozzles.
  - \* Check the spray pattern. Usually you can see the coverage better on a solid concrete surface, such as a driveway.

## Maintenance During/After Spraying

Periodically check the strainer on the sprayer and clean the screen on your intake line.

If sprayer becomes clogged during use, discontinue use immediately. DO NOT attempt to service while chemicals are in the sprayer and power is connected.

Proper care and maintenance will prolong the life of your sprayer.

After use, drain the tank and store or dispose of chemical properly. Fill the sprayer half way with clean water. Start the pump and allow the water to pump through the entire plumbing system and nozzles. Drain and then refill half full, add the recommended amount of a good quality tank cleaner, such as FIMCO Tank Neutralizer and Cleaner. (If no tank cleaner is available, you may substitute dish soap for this step, about 1-2 oz. per gallon). But a neutralizer/cleaner should be used to thoroughly clean the system. Turn pump on and circulate through system for 15 minutes and then spray out through boom and handgun nozzles. Refill sprayer half way with clean water and repeat. Follow the chemical manufacturer's disposal instructions of all wash or rinsing water. Remove the tips and screens from the nozzle assemblies. Wash these items out thoroughly. Blow the orifice clean and dry. If the orifice remains clogged, clean it with a fine bristle (NOT WIRE) brush or with a toothpick. Do not damage the orifice. Water rinse and dry the tips before storing.

**WARNING:** Some chemicals will damage the pump valves if allowed to soak untreated for a length of time! ALWAYS flush the pump as instructed after each use. DO NOT allow chemicals to sit in the pump for extended times of idleness. Follow the chemical manufacturer's instructions on disposal of all waste water from the sprayer.

**CAUTION:** Never use a metal object or other sharp item for cleaning a nozzle tip. It is better to use a nozzle brush (NOT wire brush) or compressed air for tip cleaning.

## Winter Storage

It is essential that you winterize your sprayer to avoid damage and to allow for optimal performance. The winterization process should be undertaken before freezing conditions and/or after each season of use.

Before storing your sprayer for winter or long term storage, thoroughly clean and drain it as much as possible. Then pour enough antifreeze into the tank so that when the pump is turned on you can pump the antifreeze throughout the entire plumbing system, including the bypass. Make sure to operate the boom and handgun until you see fluid spraying from the nozzles. Leave any remaining antifreeze in the tank. Before your next usage, rinse the antifreeze from the sprayer with clean water.

It is nearly impossible to drain all of the water from the sprayer and any trapped water can freeze in cold weather and damage parts of the sprayer. Pumping the antifreeze through the system will displace the water and help prevent this damage.

1. Verify that the tank is empty and rinsed out. Pour 1-2 gallons of antifreeze into the tank.
  - A. 12-Volt Pump, use pink RV Antifreeze through the system. This will keep internal parts lubricated, protect against corrosion and keep the unit from freezing.

*Note: RV antifreeze is non-toxic and biodegradable and generally safer for the environment than automotive antifreeze.*
  - B. Roller Pump, use a solution of automotive antifreeze (containing a rust inhibitor) through the entire plumbing system.
2. Engage the pump and spray with the boom and spray gun (if applicable). Make sure that the antifreeze has been pumped through the entire system, including all spray nozzles.
3. Before spraying in the spring, it is recommended to flush the sprayer with fresh water to cleanse it of the antifreeze and any other buildup. It would also be beneficial to do a thorough inspection of all sprayer components before spraying.

Removing from storage: drain the antifreeze. Fill the tank with fresh water and run through the system. Dispose of antifreeze and flush water properly.

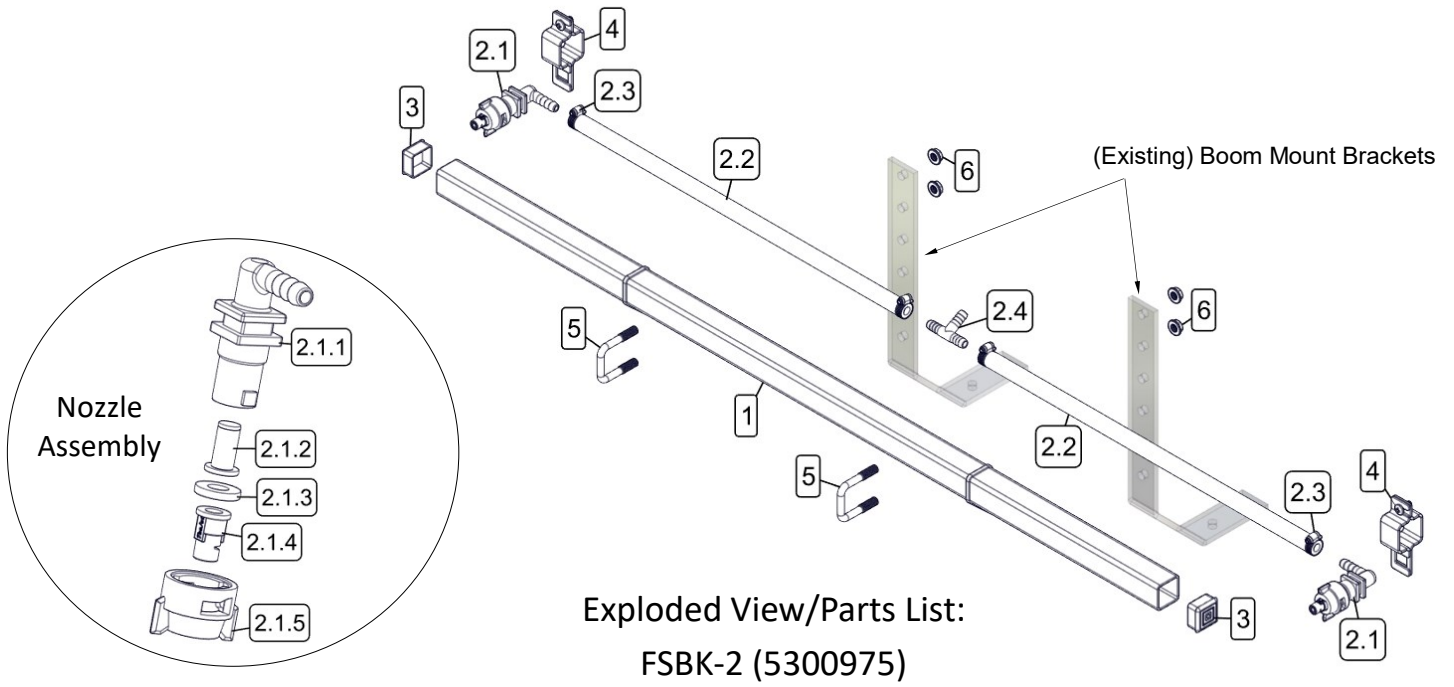

Exploded View/Parts List:  
FSBK-2 (5300975)

Ref. #	Part #	Description	Qty
1	5009321-BLK	Boom Tube	1
2	5277692	2-Nozzle Harness (3/8")	1
2.1	5281306	ELL Nozzle Sub-Assembly (3/8")	2
2.1.1	5056113	Single Hose Shank (3/8" Hose)	1
2.1.2	5143543	Check Valve Strainer, 50 Mesh, 5 PSI	1
2.1.3	5016157	Seat Washer (QJ Caps)	1
2.1.4	5018274	Turbo FloodJet Tip (TF-VP3)	1
2.1.5	5046251	QJ Cap Only (Black)	1
2.2	5020531	Hose, 3/8"-1 Brd. x 19-3/8"	2
2.3	5051144	Hose Clamp, 3/8"	4

Ref. #	Part #	Description	Qty
2.4	5086025	Poly Hose Tee, 3/8" HB	1
3	5046344	Square Cap, Black (1 1/4" Square)	2
4	5272165	Vari-Quick Clamp (1 1/4" Sq. Tube)	2
5	5034159	Square U-Bolt, 5/16" x 1 5/16" x 1 7/8"	2
6	5006307	5/16"-18 Hex Whiz (Flange) Locknut	4
7	5277926	1/2" Hose to 3/8" Hose Conversion Kit	1
7.1	5067228	1/2" x 3/8" Poly Hose Mender	1
7.2	5020417	Hose, 3/8"-1 Brd. x 5-1/2"	1
7.3	5051144	Hose Clamp, 3/8"	2

Based on the minimum overlap required to obtain uniform distribution with 120° tips and 40" spacing.

Suggested Minimum Spray Height: 18"-20" above what is being sprayed (to plant, not ground).

Optimum Spray Height: 39"

Wide angle spray nozzle height is influenced by nozzle orientation. The critical factor is to achieve a minimum 30% overlap.

- Excellent spray distribution for uniform coverage along the boom.
- Nozzle design incorporates a pre-orifice to produce larger droplets for less drift.

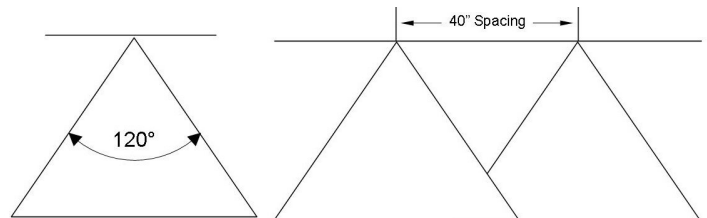

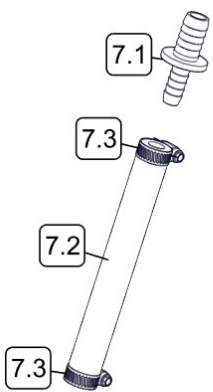

### 1/2" to 3/8" Conversion Kit (5277926)

If your existing sprayer has a 1/2" I.D. hose supplying your original boom and you now have a boom with 3/8" I.D. hose, this conversion kit allows you to easily convert your supply line to fit onto the 3/8" I.D. hose of your new boom.

Slip hose mender's 1/2" barb (larger side) into your existing 1/2" feeder hose and clamp in place with (existing) original hose clamp. Slip the (included) 3/8" hose (5-1/2" long) onto the 3/8" barb of the hose mender and clamp in place with one of the supplied hose clamps.

Now attach the open end of the hose onto the fitting on your boom which accepts the feeder line hose. Make sure to place the hose clamp onto that hose prior to attaching it to boom.

# Warranty

## LIMITED WARRANTY FOR NEW AG SPRAY EQUIPMENT

**WHO MAY USE THIS LIMITED WARRANTY.** This limited warranty (the "Limited Warranty") is provided by Ag Spray Equipment to the original purchaser ("you") of the Equipment (as defined below) from Ag Spray Equipment or one of Ag Spray Equipment's authorized dealers. This Limited Warranty does not apply to any subsequent owner or other transferee of the Equipment. THIS LIMITED WARRANTY GIVES YOU SPECIFIC LEGAL RIGHTS, AND YOU MAY ALSO HAVE OTHER RIGHTS WHICH VARY FROM STATE TO STATE.

**WHAT THIS LIMITED WARRANTY COVERS AND FOR HOW LONG.** Ag Spray Equipment warrants that any new Equipment will be free from defects in material and workmanship for a period of **one (1) year** after delivery of the Equipment to you (the "Warranty Period"). The Warranty Period is not extended if Ag Spray Equipment repairs or replaces the Equipment.

**WHAT IS NOT COVERED BY THIS LIMITED WARRANTY.** This Limited Warranty does not apply to: (1) used Equipment; (2) any Equipment that has been altered, changed, repaired or treated since its delivery to you, other than by Ag Spray Equipment or its authorized dealers; (3) damage or depreciation due to normal wear and tear; (4) defects or damage due to failure to follow Ag Spray Equipment's operator's manual, specifications or other written instructions, or improper storage, operation, maintenance, application or installation of parts; (5) defects or damage due to misuse, accident or neglect, "acts of God" or other events beyond Ag Spray Equipment's reasonable control; (6) accessories, attachments, tools or parts that were not manufactured by Ag Spray Equipment, whether or not sold or operated with the Equipment; or (7) rubber parts, such as tires, hoses and grommets.

**HOW TO OBTAIN WARRANTY SERVICE.** To obtain warranty service under this Limited Warranty, you must (1) provide written notice to Ag Spray Equipment of the defect during the Warranty Period and within **thirty (30)** days after the defect becomes apparent or the repair becomes necessary, at the following address: Ag Spray Equipment, 1000 Fimco Lane, North Sioux City, SD 57049; and (2) make the Equipment available to Ag Spray Equipment or an authorized dealer within a reasonable period of time. For more information about this Limited Warranty, please call: **800-274-1025** or your local Ag Spray location.

**WHAT REMEDIES ARE AVAILABLE UNDER THIS LIMITED WARRANTY.** If the conditions set forth above are fulfilled and the Equipment or any part thereof is found to be defective, Ag Spray Equipment shall, at its own cost, and at its option, either repair or replace the defective Equipment or part. Ag Spray Equipment will pay for shipping and handling fees to return the repaired or replacement Equipment or part to you.

**LIMITATION OF IMPLIED WARRANTIES AND OTHER REMEDIES.** THE REMEDIES DESCRIBED ABOVE ARE YOUR SOLE AND EXCLUSIVE REMEDIES, AND AG SPRAY EQUIPMENT'S SOLE LIABILITY, FOR ANY BREACH OF THIS LIMITED WARRANTY. TO THE EXTENT APPLICABLE, ANY IMPLIED WARRANTIES, INCLUDING, WITHOUT LIMITATION, THE IMPLIED WARRANTIES OF MERCHANTABILITY AND FITNESS FOR A PARTICULAR PURPOSE, SHALL BE LIMITED IN DURATION TO THE WARRANTY PERIOD, AND THE REMEDIES AVAILABLE FOR BREACH THEREOF SHALL BE LIMITED TO THE REMEDIES AVAILABLE UNDER THIS EXPRESS LIMITED WARRANTY. SOME STATES DO NOT ALLOW LIMITATIONS ON HOW LONG AN IMPLIED WARRANTY LASTS, SO THE ABOVE LIMITATION MAY NOT APPLY TO YOU. IN NO EVENT SHALL AG SPRAY EQUIPMENT'S LIABILITY UNDER THIS LIMITED WARRANTY EXCEED THE ACTUAL AMOUNT PAID BY YOU FOR THE DEFECTIVE EQUIPMENT, NOR SHALL AG SPRAY EQUIPMENT BE LIABLE, UNDER ANY CIRCUMSTANCES, FOR ANY CONSEQUENTIAL, INCIDENTAL, SPECIAL OR PUNITIVE DAMAGES OR LOSSES, WHETHER DIRECT OR INDIRECT. SOME STATES DO NOT ALLOW THE EXCLUSION OR LIMITATION OF INCIDENTAL OR CONSEQUENTIAL DAMAGES, SO THE ABOVE LIMITATION OR EXCLUSION MAY NOT APPLY TO YOU.